

Unit: inch(mm)

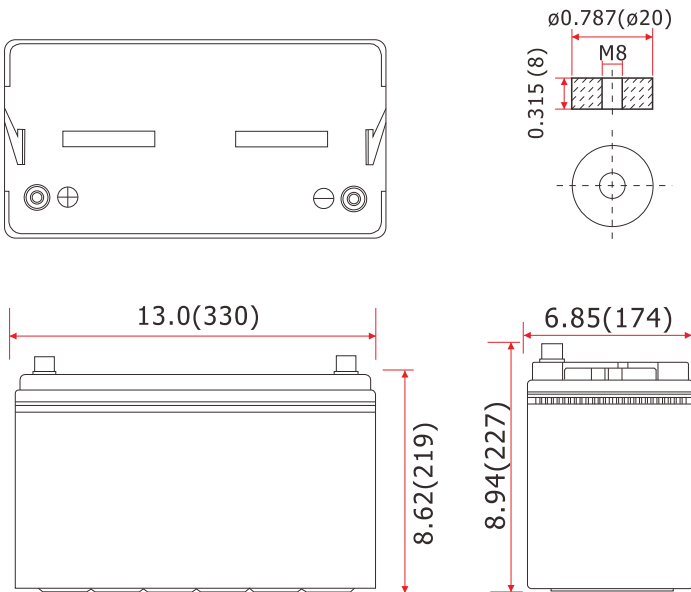

### Discharge Current and Discharge Duration Time

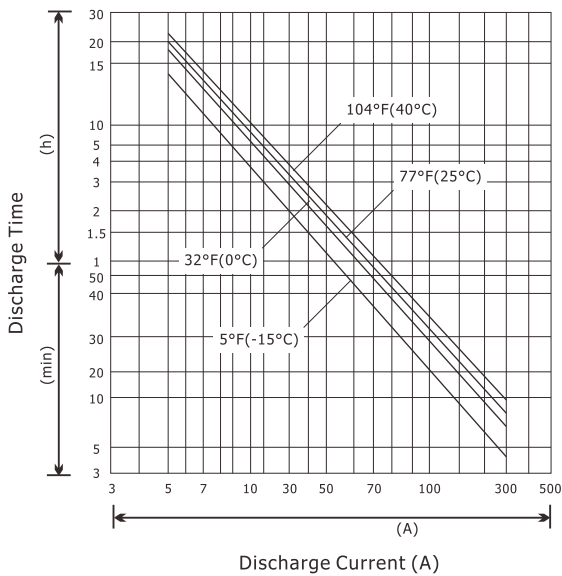

Discharge Curves 77°F(25°C)

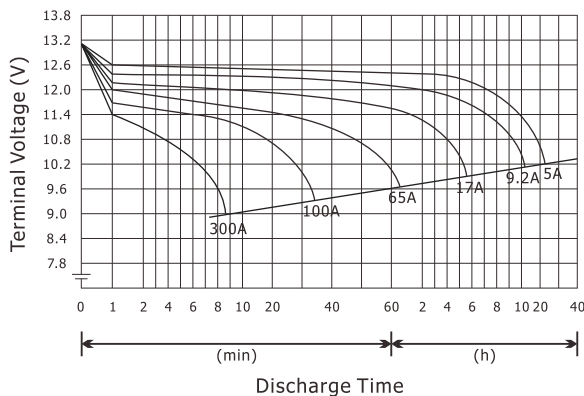

### Specification

Nominal Voltage	12V	
Rated Capacity (20hr Rate)	100Ah	
Dimensions	Length	13.0inches (330mm)
	Width	6.85inches (174mm)
	Height	8.62inches (219mm)
Total Height	8.94inches (227mm)	
Weight	Approx. 66.14lbs (30.01kg)	
<b>Characteristics</b>		
Capacity 77°F(25°C)	20hour rate (5.0A)	100Ah
	10hour rate (9.2A)	92Ah
	5hour rate (17.0A)	85Ah
	1hour rate (65.0A)	65Ah
Internal Resistance	Full Charged, 77°F(25°C)	5mΩ
Capacity Affected By Temperature (10hr Rate)	104°F(40°C)	102%
	77°F(25°C)	100%
	32°F(0°C)	85%
	5°F(-15°C)	65%
Self-Discharge 77°F(25°C)	Capacity after 3 month storage	90%
	Capacity after 6 month storage	85%
	Capacity after 9 month storage	65%
Charge (Constant Voltage)	Initial Charge Current "LESS" than 30A	
	Cycle	14.2–14.5V/77°F(25°C)
	Stand By	13.4–13.7V/77°F(25°C)
Designed Floating Life (77°F/25°C)	10 Years	

\*\*These data are average values obtained from three Charge/Discharge cycles. Note: These are NOT minimum values.

### Constant Current Discharge Characteristics Unit: A (25°C / 77°F)

F.V/Time	5MIN	10MIN	15MIN	30MIN	1HR	2HR	3HR	5HR	8HR	10HR	20HR
9.6V	372	256	192	117	69.2	39.5	28.8	18.4	12.2	10.0	5.50
10.0V	344	241	183	113	68.0	38.7	28.4	18.1	12.0	9.80	5.40
10.2V	330	234	178	111	67.3	38.2	28.1	18.0	11.9	9.70	5.30
10.5V	303	220	170	107	65.9	37.6	27.6	17.8	11.7	9.60	5.20
10.8V	274	204	160	103	64.5	36.7	27.0	17.3	11.4	9.40	5.00
11.1V	240	183	147	99	63.4	36.0	26.0	17.0	11.2	9.30	4.80

### Constant Power Discharge Characteristics Unit: W (25°C / 77°F)

F.V/Time	5MIN	10MIN	15MIN	30MIN	1HR	2HR	3HR	5HR	8HR	10HR	20HR
9.6V	4003	2832	2218	1357	792	448	328	214	141	114	60.5
10.0V	3685	2651	2087	1318	775	442	320	210	138	112	60.0
10.2V	3509	2570	2026	1297	767	437	316	207	137	111	59.4
10.5V	3231	2408	1918	1258	752	428	310	203	134	109	58.9
10.8V	2915	2216	1801	1206	734	419	302	197	130	106	58.1
11.1V	2590	2011	1685	1152	711	408	294	192	127	103	55.2

#### Trickle / Float Service Life

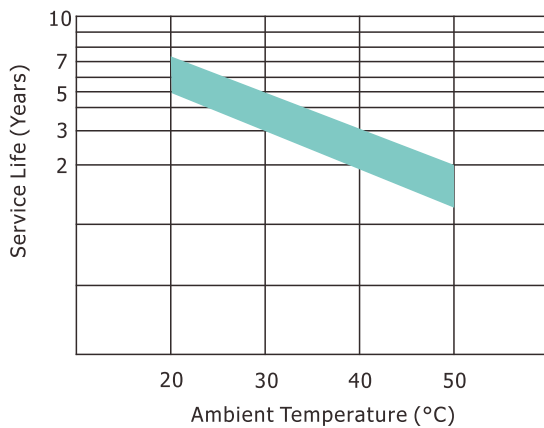

#### Effect of Temperature on Capacity

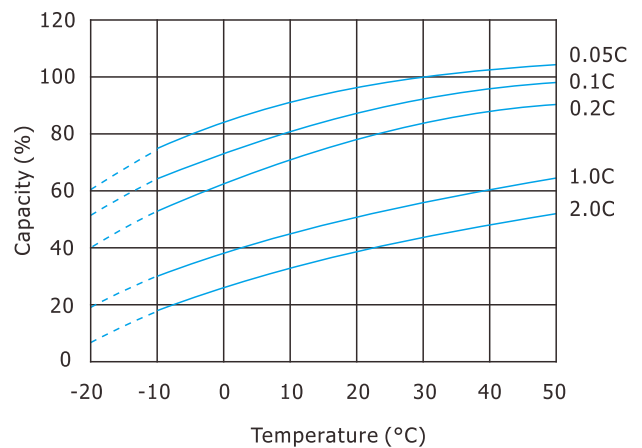

#### Cycle Service Life (@25°C/77°F)

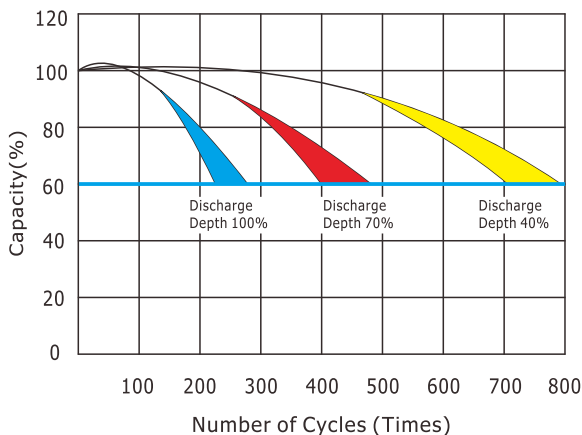

#### Capacity Retention Characteristic

